

H1 W4

A 1,2_m VI6

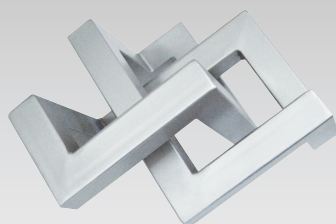

JMAFER
Saving Lives



Notified Body 2131
Reg. (UE) n. 305/11



ABNT
NBR
15486

AS-ME1.B

Sistemas de contenção viária

asebal

PARÂMETROS DE COMPORTAMENTO

Nível de contenção **H1**

Espaço de trabalho **W4**

Nível da severidade **A**

Deflexão dinâmica **1,2_m**

Intrusão **VI6**

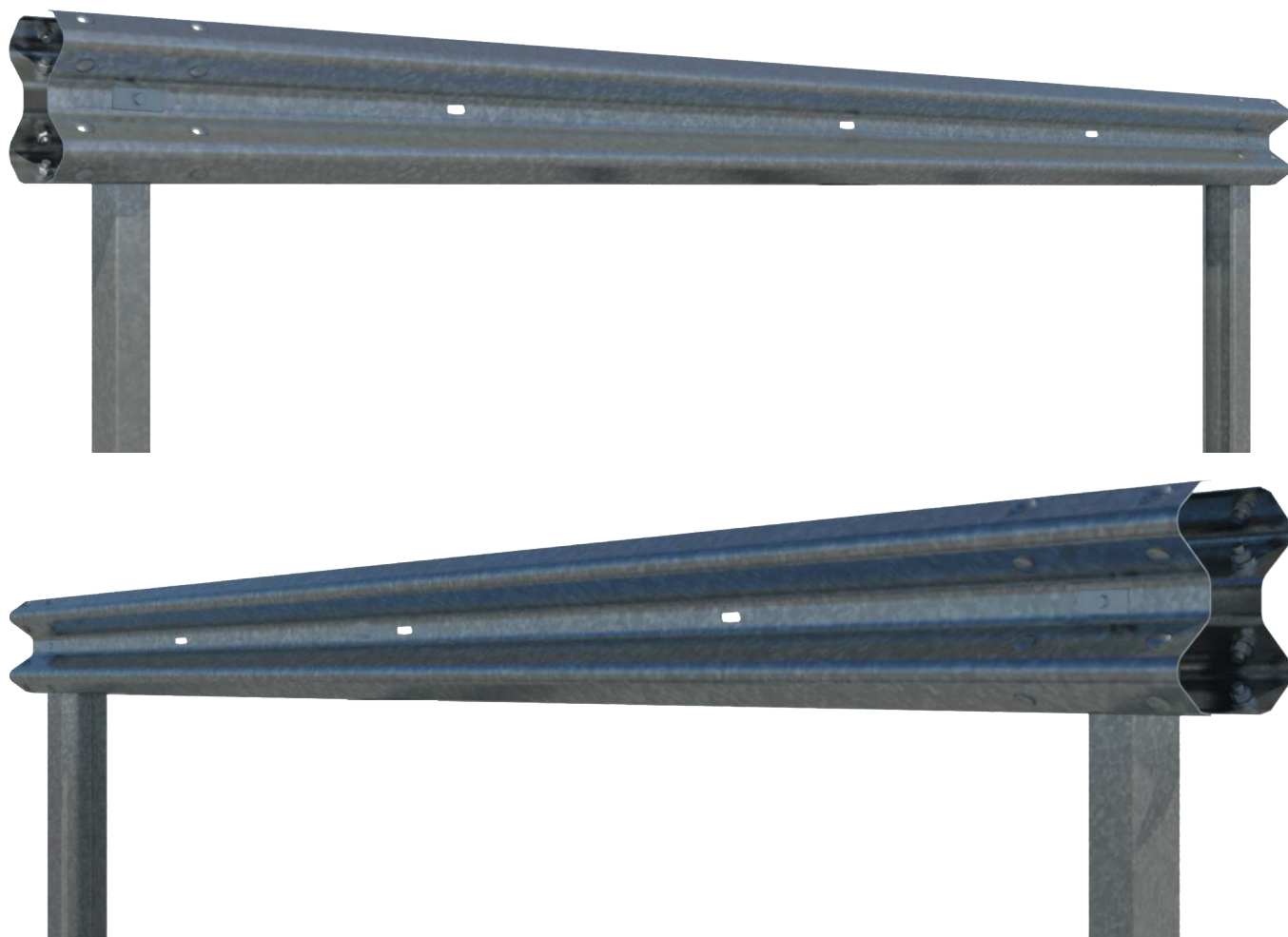

Aponte a câmera
para baixar as
fichas técnicas

JMAFER INDÚSTRIA E COMÉRCIO DE AÇOS

Rua João Roberto, 260 - Cidade Industrial Satélite Cumbica - Guarulhos - SP - CEP 07221-040

Fone: (11) 2178-8550



Atendimento:
(11) 97256-4257

H1 W4 A 1,2m VI6



Sistemas de contenção viária

asebal

COMPONENTES PARA TRAMOS DE 4 METROS

Item	Descrição	Quant.
1	Lâmina reta de 4 metros	2
2	Poste C - 125x75x20 de 1.600 mm	1
3	Parafuso de cabeça redonda M16 classe 5	16
4	Parafuso DIN 933 M10x40	2
5	Arruela Ø17x35x4 mm	16
6	Arruela retangular 100x40x5 mm Ø11 para M10	2
7	Arruela quadrada 40x40x5 mm Ø11 para M10	2
8	Porca M16	16
9	Porca M10	2

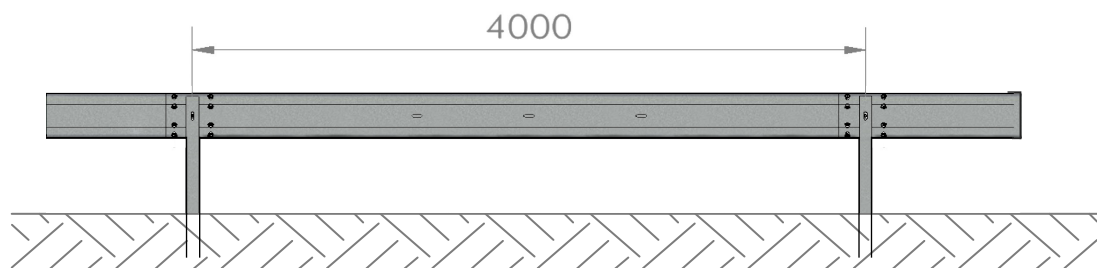
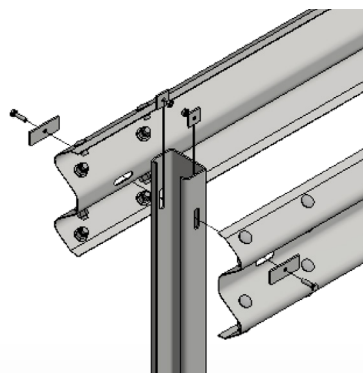
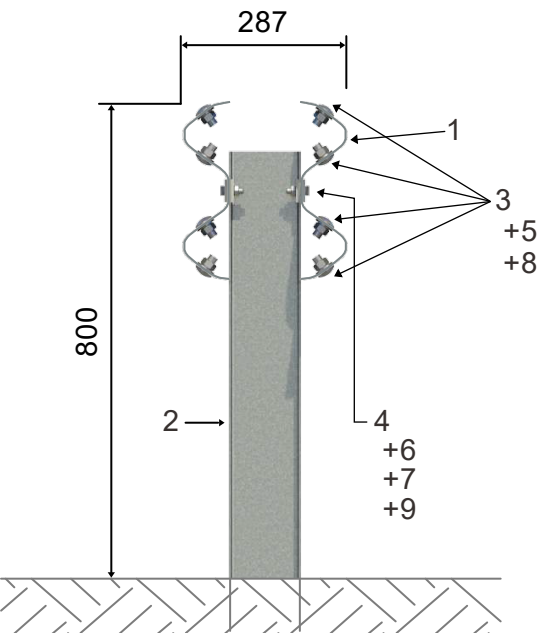

PROVAS DE IMPACTO

Ensaio: AS-ME1.B 1408

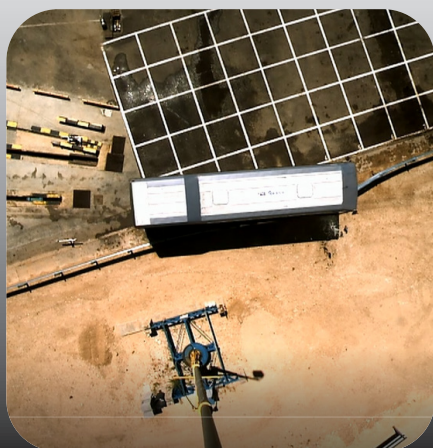

Ensaio: AS-ME1.B 1408

